

ICOM

INSTRUCTION MANUAL

VHF TRANSCEIVER

IC-2200H



Icom Inc.



---

## FOREWORD

---

Thank you for purchasing this Icom product. The IC-2200H VHF TRANSCEIVER is designed and built with Icom's superior technology and craftsmanship. With proper care, this product should provide you with years of trouble-free operation.

We want to take a couple of moments of your time to thank you for making your IC-2200H your radio of choice, and hope you agree with Icom's philosophy of "technology first." Many hours of research and development went into the design of your IC-2200H.

### ◆ FEATURES

- 65 W\* — *high transmit output power* (except Korea/Taiwan versions)
- *Tone squelch, DTCS squelch standard*
- *Dual color (amber & green) LCD backlight*
- *Remote control microphone available* (optional for some versions)
- *Optional Digital modulator/demodulator*
- *Optional DTMF decoder*

---

## IMPORTANT

---

**READ ALL INSTRUCTIONS** carefully and completely before using the transceiver.

**SAVE THIS INSTRUCTION MANUAL**— This instruction manual contains important operating instructions for the IC-2200H.

---

## EXPLICIT DEFINITIONS

---

WORD	DEFINITION
⚠ <b>WARNING!</b>	Personal injury, fire hazard or electric shock may occur.
<b>CAUTION</b>	Equipment damage may occur.
<b>NOTE</b>	Recommended for optimum use. No risk of personal injury, fire or electric shock.

Icom, Icom Inc. and the ICOM logo are registered trademarks of Icom Incorporated (Japan) in the United States, the United Kingdom, Germany, France, Spain, Russia and/or other countries.

---

## PRECAUTION

---

**⚠ WARNING RF EXPOSURE!** This device emits Radio Frequency (RF) energy. Extreme caution should be observed when operating this device. If you have any questions regarding RF exposure and safety standards please refer to the Federal Communications Commission Office of Engineering and Technology's report on Evaluating Compliance with FCC Guidelines for Human Radio frequency Electromagnetic Fields (OET Bulletin 65)

**⚠ WARNING! NEVER** connect the transceiver to an AC outlet. This may pose a fire hazard or result in an electric shock.

**⚠ WARNING! NEVER** operate the transceiver while driving a vehicle. Safe driving requires your full attention—anything less may result in an accident.

**NEVER** connect the transceiver to a power source of more than 16 V DC. This will ruin the transceiver.

**NEVER** connect the transceiver to a power source using reverse polarity. This will ruin the transceiver.

**NEVER** cut the DC power cable between the DC plug and fuse holder. If an incorrect connection is made after cutting, the transceiver may be damaged.

**NEVER** expose the transceiver to rain, snow or any liquids. The transceiver may be damaged.

**NEVER** operate or touch the transceiver with wet hands. This may result in an electric shock or ruin the transceiver.

**NEVER** place the transceiver where normal operation of the vehicle may be hindered or where it could cause bodily injury.

**DO NOT** push the PTT when not actually desiring to transmit.

**DO NOT** allow children to play with any radio equipment containing a transmitter.

During mobile operation, **DO NOT** operate the transceiver without running the vehicle's engine. When the transceiver's power is ON and your vehicle's engine is OFF, the vehicle's battery will soon become exhausted.

**BE CAREFUL!** The transceiver will become hot when operating it continuously for long periods.

**AVOID** placing the transceiver against walls or putting anything on the top of the transceiver. This will obstruct heat dissipation.

**AVOID** using or placing the transceiver in direct sunlight or in areas with temperatures below  $-10^{\circ}\text{C}$  ( $+14^{\circ}\text{F}$ ) or above  $+60^{\circ}\text{C}$  ( $+140^{\circ}\text{F}$ ).

**AVOID** the use of chemical agents such as benzine or alcohol when cleaning, as they can damage the transceiver's surfaces.

**USE** Icom microphones only (supplied or optional). Other manufacturer's microphones have different pin assignments and may damage the transceiver if attached.

# SUPPLIED ACCESSORIES AND OPTIONS

## ■ Supplied Accessories

- ① Microphone (HM-133V)\* . . . . . 1
- ② Fuse (20 A) . . . . . 1
- ③ DC power cable (3 m) . . . . . 1
- ④ Mobile mounting bracket . . . . . 1
- ⑤ Mounting screws, nuts and washers . . . . . 1 set
- ⑥ Microphone hanger† . . . . . 1
- ⑦ Insulation sheet‡ . . . . . 1

\*HM-118TN DTMF MICROPHONE supplied versions are also available.

Some versions are not supplied with a hand microphone.

†Depending on version.

‡Used for optional unit installation, see p.91 for details.

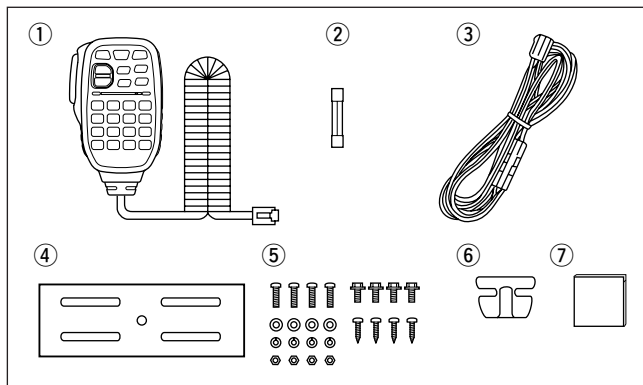

## ■ Options

**UT-108** DTMF DECODER UNIT

**UT-118** DIGITAL UNIT

**HM-118TAN/TN** DTMF MICROPHONES

**HM-118N** HAND MICROPHONE

**HM-133V** REMOTE-CONTROL MICROPHONE

**SP-10** EXTERNAL SPEAKER

**OPC-440/OPC-647** MIC EXTENSION CABLES

**OPC-441** SPEAKER EXTENSION CABLE

**OPC-1132/OPC-347** DC POWER CABLES

**OPC-589** ADAPTER CABLE

**CS-2200H** CLONING SOFTWARE

+ **OPC-478/OPC-478U** CLONING CABLE

**OPC-474** CLONING CABLE

---

# TABLE OF CONTENTS

---

FOREWORD .....	i	■ Transmitting .....	15
IMPORTANT .....	i	■ Selecting output power .....	16
EXPLICIT DEFINITIONS .....	i	■ One-touch PTT function .....	16
PRECAUTION .....	ii	<b>4 REPEATER OPERATION .....</b>	<b>17–23</b>
SUPPLIED ACCESSORIES AND OPTIONS .....	iii	■ Accessing a repeater .....	17
TABLE OF CONTENTS .....	iv	■ Subaudible tones .....	19
<b>QUICK REFERENCE GUIDE .....</b>	<b>I–VI</b>	■ Offset frequency .....	21
■ Installation .....	I	■ Repeater lockout .....	21
■ Your first contact .....	IV	■ Reversed duplex mode .....	22
■ Repeater operation .....	V	■ Auto repeater .....	23
■ Programming memory .....	VI	<b>5 MEMORY OPERATION .....</b>	<b>24–34</b>
<b>1 PANEL DESCRIPTION .....</b>	<b>1–8</b>	■ General description .....	24
■ Front panel .....	1	■ Memory channel selection .....	24
■ Function display .....	3	■ Programming a memory channel .....	25
■ Rear panel .....	5	■ Transferring memory contents .....	27
■ Microphone (HM-133V) .....	6	■ Programming channel names .....	29
■ Microphone keypad .....	7	■ Memory clearing .....	31
<b>2 SETTING A FREQUENCY .....</b>	<b>9–12</b>	■ Memory bank selection .....	32
■ Preparation .....	9	■ Memory bank setting .....	33
■ Using the tuning dial .....	9	■ Transferring bank contents .....	34
■ Using the keypad .....	10	<b>6 CALL CHANNEL OPERATION .....</b>	<b>35–36</b>
■ Using the [▲]/[▼] keys .....	10	■ Call channel selection .....	35
■ Tuning step selection .....	11	■ Call channel transferring .....	35
■ Lock functions .....	12	■ Programming a call channel .....	36
<b>3 BASIC OPERATION .....</b>	<b>13–16</b>	<b>7 SCAN OPERATION .....</b>	<b>37–42</b>
■ Receiving .....	13	■ Scan types .....	37
■ Monitor function .....	13	■ Scan start/stop .....	38
■ Audio mute function .....	14	■ Scan edges programming .....	39
■ Squelch attenuator .....	14	■ Skip channel setting .....	41
■ S-meter squelch .....	15	■ Scan resume condition .....	42

<b>8 PRIORITY WATCH</b> .....	<b>43–44</b>		
■ Priority watch types .....	43		
■ Priority watch operation .....	44		
<b>9 DTMF MEMORY ENCODER</b> .....	<b>45–47</b>		
■ Programming a DTMF code .....	45		
■ Transmitting a DTMF code .....	46		
■ DTMF speed .....	47		
<b>10 POCKET BEEP AND TONE SQUELCH</b> .....	<b>48–51</b>		
■ Pocket beep operation .....	48		
■ Tone/DTCS squelch operation .....	50		
■ Tone scan .....	51		
<b>11 PAGER/CODE SQUELCH (Required Optional UT-108)</b> .....	<b>52–57</b>		
■ Pager function .....	52		
■ Code programming .....	52		
■ Pager operation .....	55		
■ Code squelch .....	57		
<b>12 DIGITAL MODE OPERATION (Required Optional UT-118) ....</b>	<b>58–73</b>		
■ Digital mode operation .....	58		
■ Call sign programming .....	58		
■ Digital voice mode operation .....	61		
■ When receiving a Digital call .....	63		
■ Break-in communication .....	65		
■ EMG communication .....	66		
■ Digital code/Call sign squelch operation .....	67		
■ Slow data communication .....	68		
■ Other setting items .....	69		
■ GPS operation .....	72		
<b>13 OTHER FUNCTIONS</b> .....	<b>74–87</b>		
■ Set mode .....	74		
■ Initial set mode .....	79		
		■ Weather channel operation .....	83
		■ Microphone keys .....	84
		■ Partial reset .....	85
		■ All reset .....	85
		■ Data cloning .....	86
		<b>14 SPECIFICATIONS</b> .....	<b>88</b>
		<b>15 MAINTENANCE</b> .....	<b>89–91</b>
		■ Troubleshooting .....	89
		■ Fuse replacement .....	90
		■ Optional unit installation .....	91
		<b>16 CE</b> .....	<b>92</b>
		<b>17 MODE ARRANGEMENT</b> .....	<b>93–94</b>

# QUICK REFERENCE GUIDE

## ■ Installation

### ◇ Location

Select a location which can support the weight of the transceiver and does not interfere with driving in any way. We recommend the locations shown in the diagram below.

**NEVER** place the transceiver where normal operation of the vehicle may be hindered or where it could cause bodily injury.

**NEVER** place the transceiver where air bag deployment may be obstructed.

**DO NOT** place the transceiver where hot or cold air blows directly onto it.

**AVOID** placing the transceiver in direct sunlight.

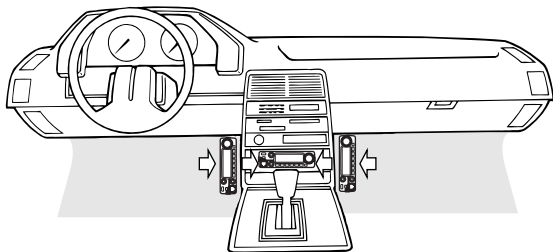

### ◇ Using the mounting bracket

- ① Drill 4 holes where the mounting bracket is to be installed.
  - Approx. 5.5–6 mm (1/4") when using nuts; approx. 2–3 mm (1/8") when using self-tapping screws.
- ② Insert the supplied screws, nuts and washers through the mounting bracket and tighten.
- ③ Adjust the angle for the clearest view of the function display.

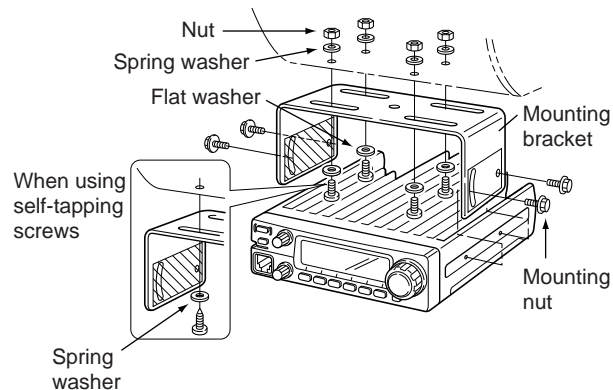

### /// IMPORTANT!

Detailed installation notes for Icom mobile transceivers to be fitted into vehicles are available. Contact your Icom dealer or distributor.



◇ **Battery connection**

- ⚠ **NEVER** connect the transceiver directly to a 24 V battery.
- ⚠ **DO NOT** use the cigarette lighter socket for power connections. (See p. 5 for details)

Attach a rubber grommet when passing the DC power cable through a metal plate to prevent short circuiting.

• **CONNECTING TO A DC POWER SOURCE**

- See p. 90 for fuse replacement.

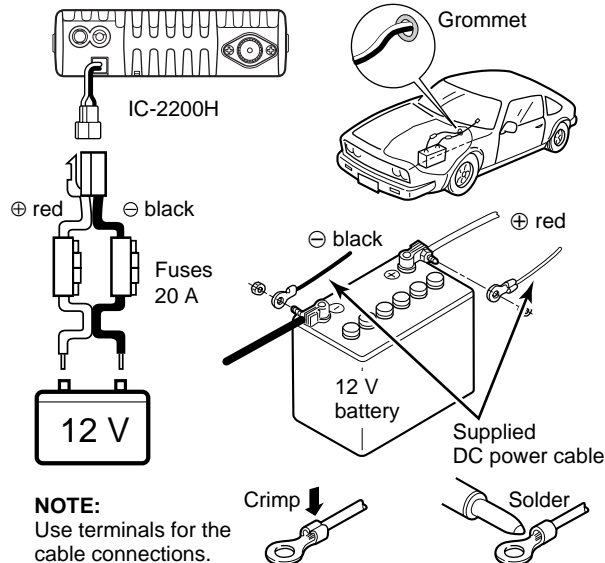

**NOTE:**  
Use terminals for the cable connections.

◇ **DC power supply connection**

Use a 13.8 V DC power supply with at least 15 A capacity.

Make sure the ground terminal of the DC power supply is grounded.

• **CONNECTING TO A DC POWER SUPPLY**

- See p. 90 for fuse replacement.

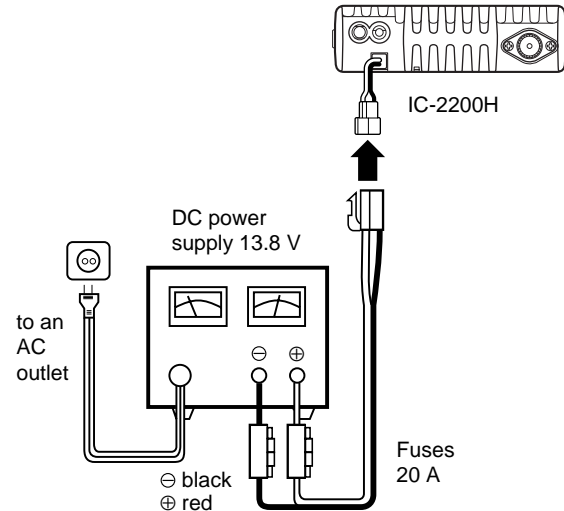

## QUICK REFERENCE GUIDE

### ◇ Antenna installation

#### • Antenna location

To obtain maximum performance from the transceiver, select a high-quality antenna and mount it in a good location. A non-radial antenna should be used when using a magnetic mount.

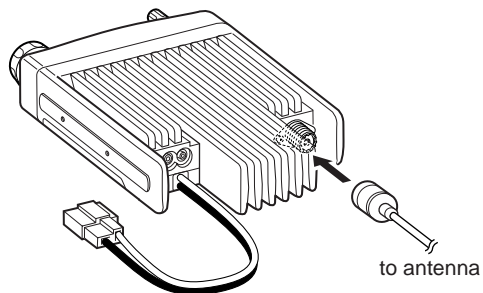
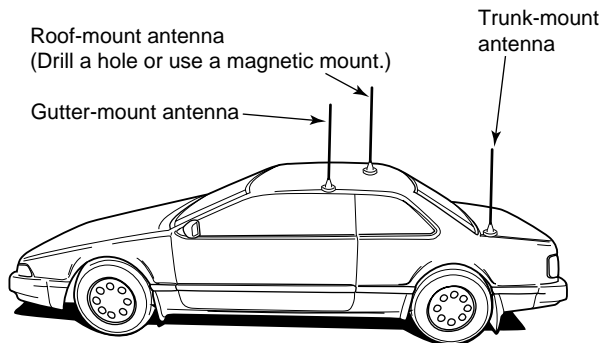

#### • Antenna connector

The antenna uses a PL-259 connector.

#### • PL-259 CONNECTOR

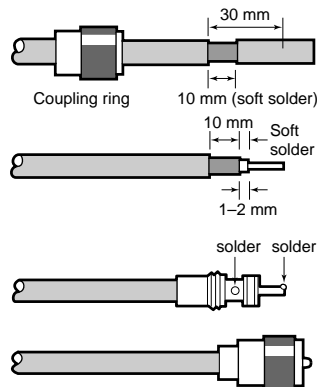

① Slide the coupling ring down. Strip the cable jacket and soft solder.

② Strip the cable as shown at left. Soft solder the center conductor.

③ Slide the connector body on and solder it.

④ Screw the coupling ring onto the connector body.  
(10 mm  $\approx$  3/8 in)

/// **NOTE:** There are many publications covering proper antennas and their installation. Check with your local dealer for more information and recommendations.

### ◇ Connecting a microphone

Connect a microphone to the eight-pin modular socket on the front panel of the transceiver.

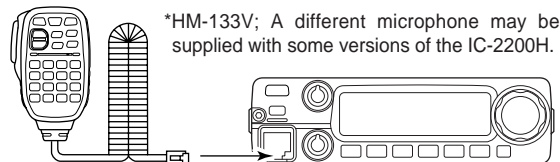

## ■ Your first contact

Now that you have your IC-2200H installed in your car or shack, you are probably excited to get on the air. We would like to take you through a few basic operation steps to make your first "On The Air" an enjoyable experience.

### 1. Turning ON the transceiver

Before powering up your IC-2200H, you may want to make sure the audio volume and squelch level controls are set in 9–10 o'clock positions.

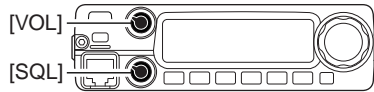

Set both [VOL] and [SQL] controls to 9–10 o'clock positions.

Although you have purchased a brand new transceiver, some settings may be changed from the factory defaults because of the QC process. Resetting the CPU is necessary to start from factory default.

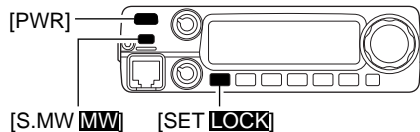

➔ While pushing **[SET LOCK]** and **[S.MW MW]**, push **[PWR]** for 1 sec. to reset the CPU.

### 2. Tune the desired frequency

**[DIAL]** will allow you to dial in the frequency you want to operate. Pages 9 and 11 will instruct you on how to set the tuning speed.

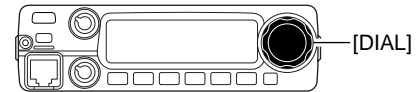

### Using the HM-133V

You can directly enter the frequency with the HM-133V keypad.

**[EXAMPLE]:** Setting frequency to 145.3625 MHz.

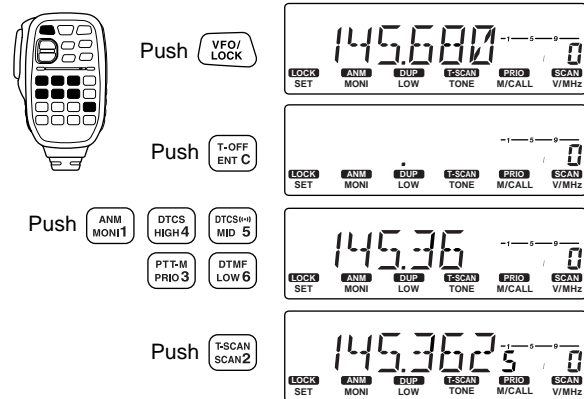

We hope these pointers have been helpful. Now you are ready to call CQ.

**Count on us!**

#02 Europe  
#12 Europe-1

<Intended Country of Use>			
<input checked="" type="checkbox"/> GER	<input checked="" type="checkbox"/> FRA	<input checked="" type="checkbox"/> ESP	<input checked="" type="checkbox"/> SWE
<input checked="" type="checkbox"/> AUT	<input checked="" type="checkbox"/> NED	<input checked="" type="checkbox"/> POR	<input type="checkbox"/> DEN
<input checked="" type="checkbox"/> GBR	<input type="checkbox"/> BEL	<input checked="" type="checkbox"/> ITA	<input checked="" type="checkbox"/> FIN
<input checked="" type="checkbox"/> IRL	<input checked="" type="checkbox"/> LUX	<input type="checkbox"/> GRE	<input type="checkbox"/> SUI
<input checked="" type="checkbox"/> NOR			